

Test Report

Product Name:	1580nm DFB Laser	Test By:	03
P/N:	BFLD-1580-10SM-FA2	Test Date:	2025/10/29

Temperature: 25°C(15~35°C)

Wavelength range: 1580 ± 1nm

Output power range: ≥10mW

Operating current < 90mA

Pigtail type: SM fiber; FC/APC connector

S/N	TX							
	Center wavelength	Operating current	Threshold current	Bias voltage	Monitor PD current	SMSR	TEC Voltage	TEC Current
	λ_p (nm)	I_o (mA)	I_{TH} (mA)	V_f (V)	I_m (uA)	SMSR(dB)	V_{TEC} (mV)	I_{TEC} (mA)
2525477001	1579.00	52.22	8.32	1.00	117.00	47.471	-400.00	160.00

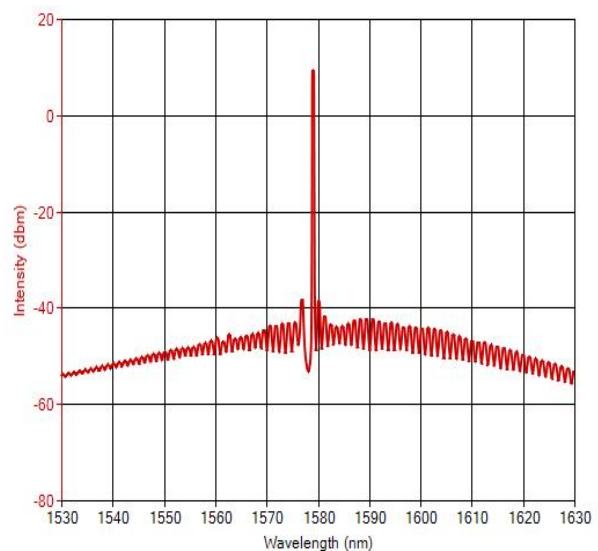
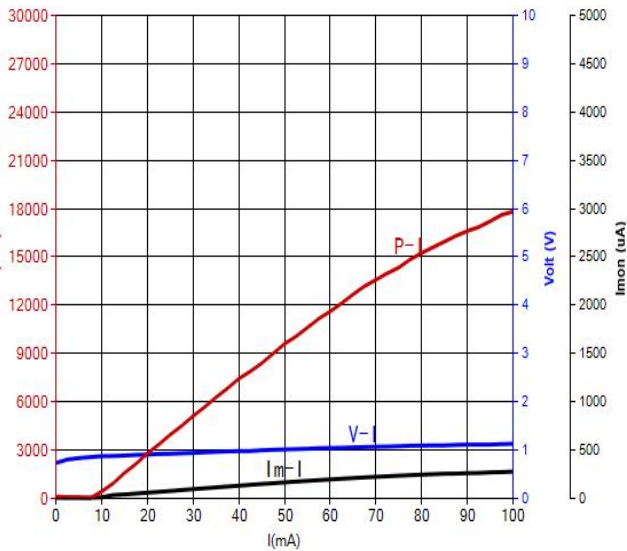

PIV Curve

Optical mapping

PIN Definition:

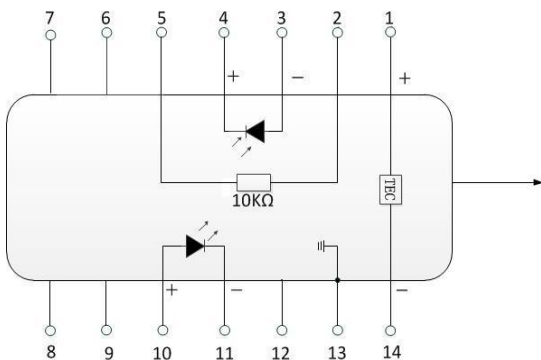

1	TEC(+)	14	TEC(-)
2	Thermistor	13	Case Ground
3	PD Monitor Anode (-)	12	NC
4	PD Monitor cathode(+)	11	Laser Cathode (-)
5	Thermistor	10	Laser Anode (+)
6	NC	9	NC
7	NC	8	NC

Attention notes

1. The electric sensitive element, please obey the static sensitive element protection
2. Pins is easy to break, please don't bend it for big angle.
3. The fiber is easy to break, when bend the fiber, the radius must is up to 20mm;
4. Ensure the plane of fiber connection is clean, which will influence the function of module.